

# QLINE DUAL-WATTAGE BATTEN

QLINE-WS-1800NW/EM



LIGHTING & SECURITY



**3HR**  
EMERGENCY  
3W BATTERY

**44-50W**  
POWER

**5YR**  
WARRANTY  
**1YR**  
ON-SITE

**IP20**

**5280-6000**  
LUMENS



Driver as Standard



LED's inside

## TECHNICAL DRAWINGS

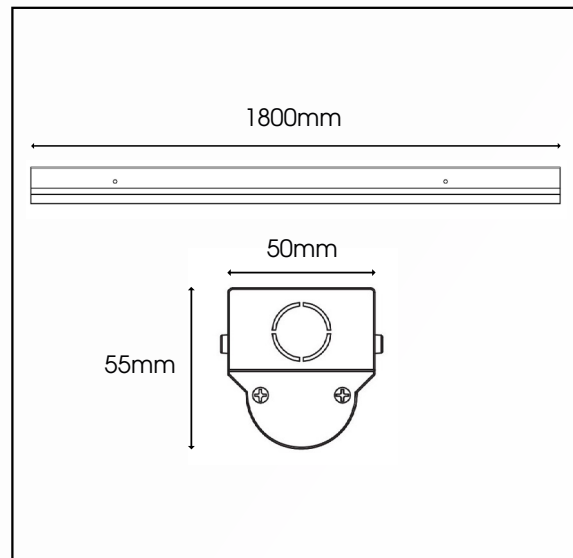

Specification	QLINE WS 1800
System Power	44-50W (Emergency 3W)
LED Chipset	Epistar
Driver Manufacturer	Boke
Colour Rendering Index	>85
Lumen Output	5280 - 6000Lm (Emergency 360Lm)
LED Efficacy	120 Lm/cW
Power Factor	0.9
IP Rating	IP20
Beam Spread	120 °
Colour Temperature	4000K
Housing Material	Aluminium
Diffuser Type	Polycarbonate
Operating Temperature	-20 to 50 °C
Input Voltage	AC 200-240V, 47-63Hz
Weight	1.5kg
Dimensions	1800mm x 50mm x 55mm
MacAdam Step	<3
Lifetime	50,000 hours, L70-B10 (Ta 25 °C)
Emergency Output	3 Hours (3W)*
CE Standard	EN60598-1, EN62493, EN55015, EN61547, EN61000-3-2, EN61000-3-3, EN62722-1, EN62722-2-1 and EN50581
CE Directives	LVD, EMC, ERP & RoHS

\* Warranty terms and conditions apply

\*For emergency products with a rated service life of < 50,000 operating hours, QVIS offers a 5-year warranty period on the luminaire and 1-year warranty period on the battery pack

## LUMINOUS INTENSITY DISTRIBUTION DIAGRAM

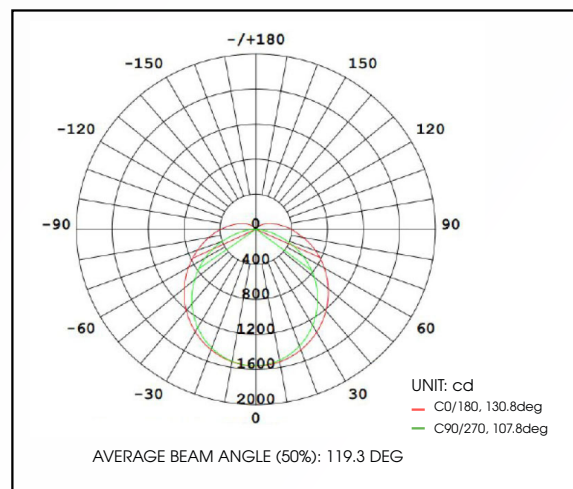

SURFACE & SUSPENDED RANGE