

Continuous Linear



Various Mounting Options



Wattage Switchable



1-10V Dimmable (As Standard)



Tri-Colour (3000K/4000K/5000K)

Dimensions

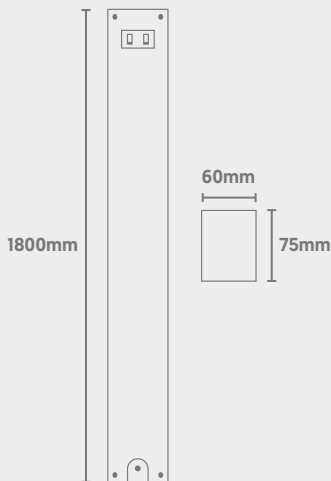

A
↑
G **E** Light Source Energy Rating

Photometric Data

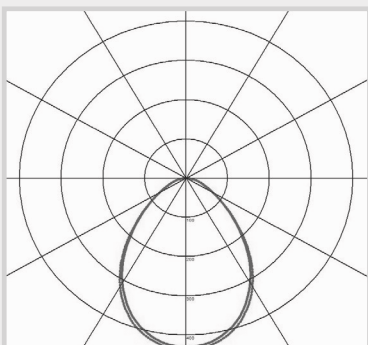

SpecLine

Direct Linear

QVIS[®]

LIGHTING & SECURITY

CODE: SPECLINE-WS-1800TC/EM



3HR
EMERGENCY
DURATION

5
YEARS
WARRANTY
+ 1 YEAR ON SITE*

Power (Selectable)	Efficacy	Output	Kelvin
36W [Emergency 3W]	120Lm/cW	4320Lm [Emergency 360Lm]	Tri-Colour: 3000K, 4000K or 5000K
48W [Emergency 3W]	120Lm/cW	5760Lm [Emergency 360Lm]	
60W [Emergency 3W]	120Lm/cW	7200Lm [Emergency 360Lm]	

Technical

Input Voltage	AC 200-240V
Colour Rendering Index	>80
Beam Spread	110°
Diffuser Type	Microprismatic
Operating Temp.	-20 to +45°C
Materials	Aluminium & Polycarbonate
IP Rating	IP20
Dimmable	1-10V (as Standard)
Dimensions	1800mm x 75mm x 60mm
Weight	3.4kg
MacAdam Step	<3
Emergency Output	3 Hours [3W]
Lifetime	50,000 hours, L70-B10 [Ta 25 °C]
CE Standards	EN60598-1, EN62493, EN55015, EN61547, EN61000-3-2, EN61000-3-3, EN62722-1, EN62722-2-1 and EN50581
CE Directives	LVD, EMC, ERP & RoHS