

External



IP66 Ingress Protection



IK10 Impact Resistance



10Kv Surge Protection



60mm or 76mm Spigot Size

Dimensions

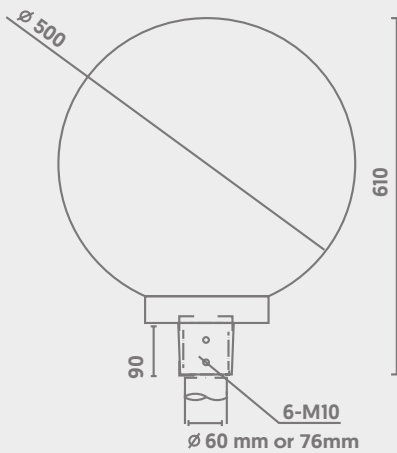

Photometric Data

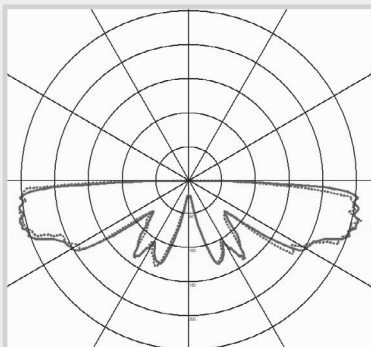

QGlobe

Post-Top Luminaire

CODE: QGLOBE-WS-500-2CCT

QVIS[®]
LED LIGHTING



Power	Efficacy	Output	Kelvin
30W	108Lm/cW	3240Lm	Dual-Colour: 3000K or 4000K
45W	108Lm/cW	4860Lm	
60W	108Lm/cW	6480Lm	

Technical

Input Voltage	AC 220-240V
Colour Rendering Index	>80
Dimmable	On Request
Operating Temp.	-25 to +50°C
Cover Material	PMMA
Base Materials	Die-Cast Aluminium
IP Rating	IP66
IK Rating	IK10
Surge Protection	10Kv
Weight	5.4kg
MacAdam Step	<3
Lifetime	50,000 hours, L90-B10 (Ta 40 °C)
CE Standards	EN60598-1, EN62493, EN55015, EN61547, EN61000-3-2, EN61000-3-3
CE Directives	LVD, EMC, RoHS

External



IP66 Ingress Protection



IK08 Tempered Glass Lens



10Kv Surge Protection



Asymmetric Beam

QStreet Pro Gen 2

Street Lighting



CODE: QSTREET2-PRO-50NW/PH

Photocell Information

Rated Voltage	AC 110-120V
Applicable Voltage Range	AC 100-140V
Rated Frequency	50/60Hz
Rated Loading	1000W Tungsten; 1800VA Ballast
Power Consumption	1.5VA (3VA for -HP)
On/Off Level	6Lx On / 50Lx Off
Time Delay	3 to 20s
Surge Arrester	Built-In
Fail-On Mode	Supported
Lock Mechanism	ANSI C136.10-1996 Certified Twist Lock
Relative Humidity	99%
Dimensions	84mm x 66mm
Weight	0.085kg