

# Continuous Linear



Various Mounting Options



Wattage Switchable



1-10 Dimmable (As Standard)



Tri-Colour (3000K/4000K/5000K)

## Dimensions

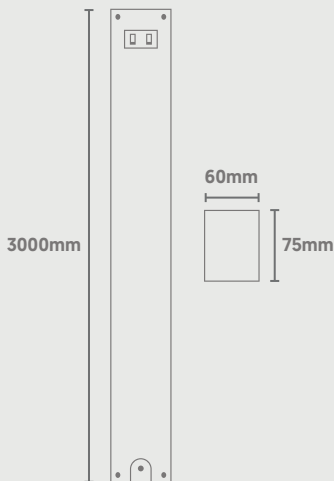

# SpecLine

## Direct Linear

**QVIS**<sup>®</sup>  
LIGHTING & SECURITY

CODE: SPECLINE-WS-3000TC

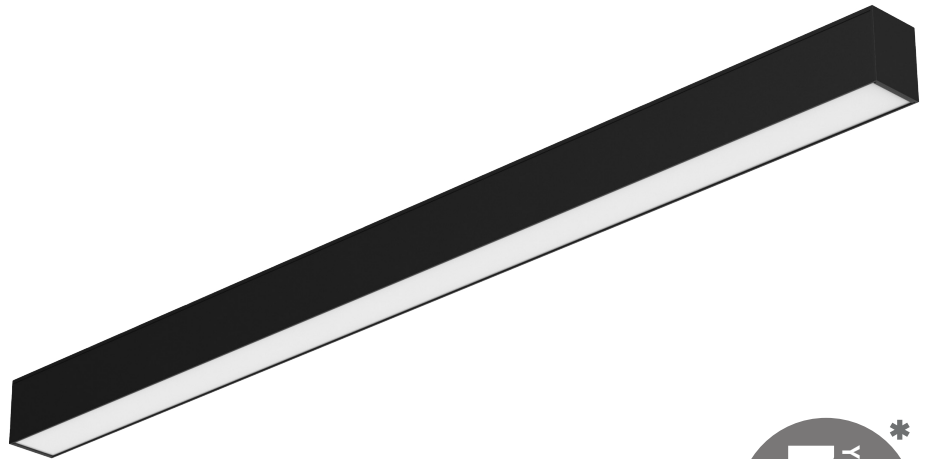

Power (Selectable)	Efficacy	Output	Kelvin
60W	120Lm/cW	7200Lm	Tri-Colour: 3000K, 4000K or 5000K
80W	120Lm/cW	9600Lm	
100W	120Lm/cW	12000Lm	

## Technical

Input Voltage	AC 200-240V
Colour Rendering Index	>80
Beam Spread	110°
Diffuser Type	Microprismatic
Operating Temp.	-20 to +45°C
Materials	Aluminium & Polycarbonate
IP Rating	IP20
Dimmable	1-10 Dimmable
Dimensions	3000mm x 75mm x 60mm
Weight	5.8kg
MacAdam Step	<3
Lifetime	50,000 hours, L70-B10 (Ta 25 °C)
CE Standards	EN60598-1, EN62493, EN55015, EN61547, EN61000-3-2, EN61000-3-3, EN62722-1, EN62722-2-1 and EN50581
CE Directives	LVD, EMC, ERP & RoHS

## Photometric Data

