



Optical Smoke Alarm

CODE: QFS-ELCON10-IS

Interlinkable

Elite Series



Features

- 10 year sealed Lithium battery (no need to change batteries)
- Interlink devices via wired connection with other alarms
- Photoelectrical sensor to detect smoke and reduce false alarms
- Compliant with EN14604:2005/AC:2008
- Alarm sounder (85dB)



GONEGT+

Specification	QFS-ELCON10-IS
Power	220-240V; 50-60Hz (with 3V battery backup)
Alarm Volume	>85dB (A) at 3m
Silence Time (Mute)	8 minutes
Compliance Standard	EN14604:2005/AC:2008
Local Heat Alarm Sound Pattern	ISO8201; (Beep 0.5s > Pause 0.5s > Beep 0.5s > Pause 0.5s > Beep 0.5s > Pause 1.5s; Accompanied by red LED flash) [repeat]
Wired Alarm Sound Pattern	Two beeps > Pause 0.5s > Two beeps > Pause 1.5s
Maximum Interlinked Devices	x40 devices
Mounting	Mount onto base

QVIS®

LIGHTING & SECURITY



Optical Smoke Alarm

CODE: QFS-ELCON10-IS

Interlinkable

Elite Series

Functions

Normal	Red LED flashes once (48 seconds); Green LED is always on	
Fault	Buzzer sound every 48 seconds (indicating a fault)	
Low Power	Buzzer sound every 48 seconds; Accompanied by yellow LED flash	
Alarm	Pulsating buzzer; Accompanied by red LED flashing every 1 second	
Mute	Silent buzzer for 8 minutes	
Test	Imitates LED & buzzer pattern as per 'Alarm Mode'	

WARNING

When the power is low, or service life reaches 10 years, the alarm should be replaced. In any doubt, an alarm trigger should be assumed to be due to a fire and appropriate measures must be taken immediately.



Optical Smoke Alarm

CODE: QFS-ELCON5-IS

Interlinkable

Elite Series

Hardwired Install & Device Linking

1) Prepare Wires	Strip the live, neutral and interconnect (if connecting other devices) wires as per diagram 1 shown below
2) Terminals	As per diagram 2, connect the wires to corresponding terminals and ensure terminal screws are properly tightened. Close the terminal cover to avoid contact with live terminals
3) Connect Devices	Devices must be linked together using the interconnect wire
4) Clip to Base	If base is screwed to the ceiling and a battery is installed, the alarms should clip on (this will not work without battery)
5) Testing	A test should be initiated before use (see previous page)

Wire Stripping

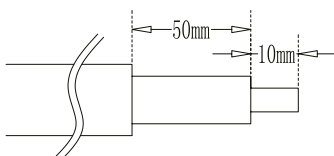

Connect Wires

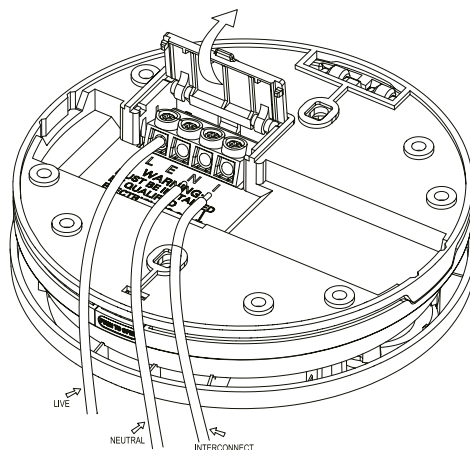

Close Terminal

